

Product information

# Nilar EC Series

- Advanced NiMH battery technology

## BENEFITS IN BRIEF

- Wide temperature range
- Safer than "Safe"<sup>1</sup>
- Long service life
- Maintenance free
- Environmentally friendly
- Recyclable from cradle to cradle

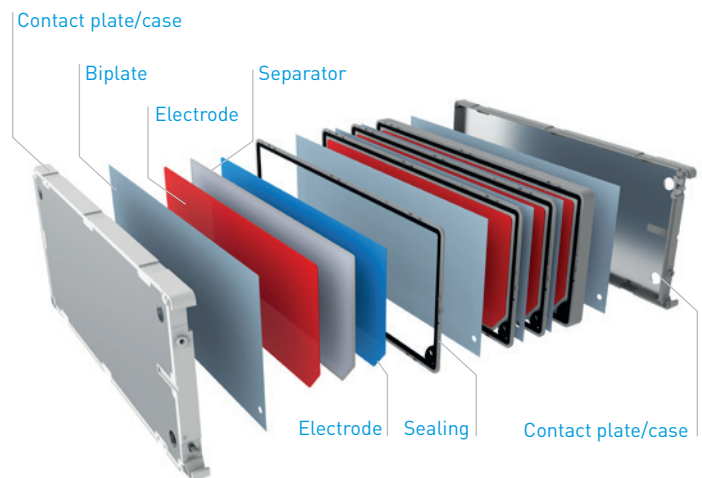

## Patented Nilar design

The Nilar EC (Energy Compact) is the only commercially available bi-polar NiMH battery. With the patented Nilar bi-polar design, the Nilar EC brings you a safer, greener, more reliable and cost-efficient energy storage solution. Thanks to the ruggedness of the Nilar NiMH design, Nilar EC delivers a stable performance curve throughout the life of the battery. With a operating temperature range covering -20°C to +50°C, you can rely on the battery to perform in various conditions. The Cradle-to-Cradle philosophy has been a central part of the R&D process for Nilar EC. Additionally, the newly patented module cooling solution ensures stable temperature throughout the whole pack.

1) Nilar provides battery systems that are safer than many so called "safe" solutions available on the market. The Nilar battery system contains water based, non-flammable electrolyte. It does not generate short circuit current/failure/conditions even under low temperature charging. The electrodes cannot ignite spontaneously and will not cause heat propagation between modules. That's why we argue that we are safer than "safe".

**Nilar AB**  
 Headquarter and sales  
 Stockholmsvägen 116 B  
 SE-187 30 Täby  
 Sweden  
 Phone: +46 (0) 8 768 00 00  
 Email: sales.europe@nilar.com

**Nilar Inc.**  
 Sales and R&D  
 10800 E. Bethandy Drive, Suite 525  
 Aurora, CO 80014  
 USA  
 Phone: +1 720 446 0169  
 Email: sales.america@nilar.com

**Nilar AB**  
 R&D and Production unit  
 Bönavägen 55, Box 8020  
 SE-800 08 Gävle  
 Sweden  
 Phone: +46 (0)26 960 90  
 Email: production@nilar.com



www.indutecc.nl  
 info@indutecc.nl 072-5412345

Integrated Monitoring Unit

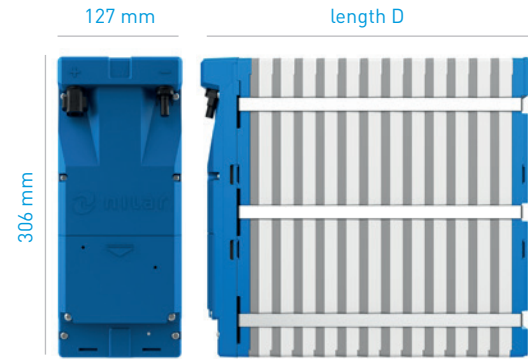
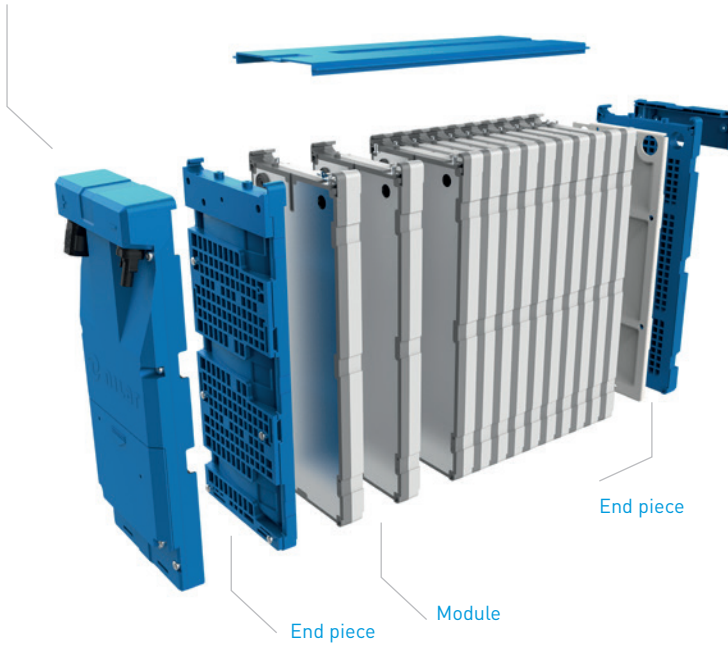

Configuration	Length D, mm
EC-96V-10Ah	248
EC-108V-10Ah	273
EC-120V-10Ah	293
EC-144V-10Ah	337

Battery pack specifications

Electrical Characteristics	96V	108V	120V	144V	Unit
Capacity	10	10	10	10	Ah
Energy	0.96	1.08	1.2	1.44	kWh
Cycles	2000	2000	2000	2000	cycles
Nominal Voltage	96	108	120	144	VDC
Max continuous charge /discharge	3 C	3 C	3 C	3 C	C-rate
Max charge/discharge:	7 C	7 C	7 C	7 C	C-rate
Gravimetric energy density	40.7	41.2	41.7	42.4	Wh/kg
Volumetric energy density	122.1	124.4	126.3	129.3	Wh/l
Mechanical Characteristics					
Dimensions (DxHxW)	248 x 306 x 127	273 x 306 x 127	293 x 306 x 127	337 x 306 x 127	mm
Weight	24	26	29	34	kg
Protection class					
Battery pack	IP54	IP54	IP54	IP54	IP
Integrated Monitoring Unit	IP21	IP21	IP21	IP21	IP
Operating Conditions					
Ambient temperature range	-20 to +50	-20 to +50	-20 to +50	-20 to +50	°C
Service life	20+	20+	20+	20+	years